DEPARTMENT OF THE ARMY TECHNICAL BULLETIN

REPAIR WELDING PROCEDURES
FOR
HOWITZER, MEDIUM, TOWED:
155-MM, M198
(1025-01-026-6648)

HEADQUARTERS, DEPARTMENT OF THE ARMY
JANUARY 1985

WARNING

All box areas to be welded will have a 0.38-in. hole drilled through skin to relieve gas accumulated during welding operation. Plug weld relief holes after completion of repair.

TECHNICAL BULLETIN)
)
 NO. 9-1025-211-34)

HEADQUARTERS
 DEPARTMENT OF THE ARMY
 Washington, DC, 11 January 1985

**REPAIR WELDING PROCEDURES
 FOR
 HOWITZER, MEDIUM, TOWED: 155-MM, M198
 (1025-01-026-6648)**

REPORTING ERRORS AND RECOMMENDING IMPROVEMENTS
 You can help improve this bulletin. If you find any mistakes or if you know of a way to improve the procedures, please let us know. Mail your letter, DA Form 2028 (Recommended Changes to Publications and Blank Forms), or DA Form 2028-2 located in the back of this manual direct to: Commander, US Army Armament, Munitions, and Chemical Command, ATTN: AMSMC-MAS, Rock Island, IL 61299-6000. A reply will be furnished to you.

TABLE OF CONTENTS

		Paragraph	Page
CHAPTER	1.	INTRODUCTION	
		Purpose	1-1
		Scope.....	1-2
		List of abbreviations.....	1-3
		General	1-4
		General repair welding data.....	1-5
CHAPTER	2	REPAIR WELDING PROCEDURES	
		Preparation for welding.....	2-1
		Crack determination	2-2
		Welding.....	2-3
CHAPTER	3	INDIVIDUAL WELD PROCEDURES	
		Multiple passes	3-1
		Cradle (12007903).....	3-2
		Travel lock assembly (12008450).....	3-3
		Frame (12008449).....	3-4
		Spade brackets (right/left 12009198/12009199)	3-5
		Firing assembly baseplate (12008500).....	3-6
APPENDIX	A.	REFERENCES	
		Forms and other publications	A-1

LIST OF ILLUSTRATIONS

Figure	Title	Page
1	General areas for repair welding	3-3
2	Repair welding procedure for channel 12007937.....	3-4
3	Repair welding procedure for plate 12007938	3-5
4	Repair welding procedure for block 12007939.....	3-6
5	Repair welding procedure for travel lock assembly brackets 12008530 and 12008531	3-7
6	Repair welding procedure for cracks in front plate 12008550.....	3-8
7	Repair welding procedure for tube 12008445 to plate 12008442	3-9
8	Repair welding procedure for plate 12008442 to end 12008446	3-10
9	Repair welding procedure for tube 12008445 to end 12008446	3-11
10	Repair welding procedure for tube 12008448 to end 12008447	3-12
11	Repair welding procedure for plate 12008442 to tube 12008448.....	3-13
12	Repair welding procedure for cracks in bottom plate 12008513 to support 12008501.....	3-14
13	Repair welding procedure for cracks in bottom plate 12008513	3-15
14	Repair welding procedure for top plate 12008514	3-16
15	Repair welding procedure for bottom plate 12008795	3-17
16	Repair welding procedure for side plate 12008799.....	3-18
17	Repair welding procedure for spade brackets (right/left) 12009198/12009199	3-19
18	Bushing 12009200 for spade bracket	3-20
19	Right spade bracket 12009198	3-20
20	Left spade bracket 12009199.....	3-20

**CHAPTER 1
INTRODUCTION**

1-1. Purpose. This bulletin provides instructions and guidance for repair welding on components of M198 howitzer in the field to prevent further cracking.

1-2. Scope.

a. The instructions in this publication are applicable to direct support, general support, and depot maintenance personnel responsible for repair welding of components on the M198 howitzer.

b. The publication provides repair welding procedures not covered by pertinent weapon manuals at direct support, general support, and depot maintenance level.

c. Personnel performing these repairs should be certified in accordance with MIL-STD-248C.

1-3. List of Abbreviations. This list includes abbreviations used in this manual.

Abbreviation	Definition
GMAW	Gas Metal Arc Welding
GTAW	Gas Tungsten Arc Welding
MIG	Metal Inert Gas
SMAW	Shielded Metal Arc Weld
TIG	Tungsten Inert Gas

1-4. General.

WARNING

All box areas to be welded will have a 0.38-in. Hole drilled through skin to relieve gas accumulated during welding operation. Plug weld relief holes after completion of repair.

a. The general nature of the procedures in this bulletin makes them applicable to a wide variety of situations requiring repair welds. The repair welds cited in this document are typical of specific structural members, joints, and defects most likely to be encountered in the field.

b. Variations to these instructions may be made at the discretion of the officer in charge.

c. Table 1-1 lists components covered by repair welding procedures in this manual.

d. Table 1-2 lists filler materials and the NSN's for repair welding procedures in this manual.

1-4. General--Continued

Table 1-1. Components Covered By Repair Welding

Drawing Number	Nomenclature	Process	Fig. No.
12008200	CRADLE ASSEMBLY	MIG	1 - 4
12008300	BOTTOM CARRIAGE ASSEMBLY	SMAW	5 - 6 12 thru 17
12008380	BOTTOM CARRIAGE	SMAW	5 - 6
12008600	TRAIL ASSEMBLY, RIGHT	MIG	15 thru 17
12008450	TRAVEL LOCK ASSEMBLY	MIG	7 thru 11
12008449	FRAME	MIG	7 thru 11
12008500	FIRING ASSEMBLY BASEPLATE	MIG	12 thru 14
12007903	CRADLE	MIG	1 thru 4
12009198	SPADE BRACKET, RIGHT	MIG	19
12009199	SPADE BRACKET, LEFT	MIG	20
12008601	TRAIL ASSEMBLY, LEFT	MIG	15 thru 17
12009201	REPAIR KIT		

Table 1-2. Filler Material National Stock Numbers

Filler Material	NSN
E70S-3	3439-00-483-8093
E7018	3439-00-550-4944
4043	3439-00-803-9496
5356	3439-00-803-9498
5556	3439-00-803-9500

1-5. General Repair Welding Data.**CAUTION**

Special care will be exercised to avoid damage to adjacent components. This may require some disassembly prior to repair welding.

Keep filler metal covered at all times. GMAW and GTAW electrodes, rods, and wire will be kept in boxes or covered with a plastic bag.

a. Only tack welds which will be completely remelted or removed prior welding may be made out of position in either the horizontal or vertical planes.

b. All materials must have a minimum temperature of 60°F (16°C) prior to initiation of any weld. In ambient temperature below 60°F (16°C), local preheat may be used to bring temperature to 60°F (160C).

c. Preheating of aluminum will not exceed 200°F (930C). When preheating is required, allow time for heat to soak in; part must be heated uniformly in the area to be welded.

d. Preheat and interpass temperatures will be in

accordance with the welding parameters included in this bulletin.

e. Clean weld joints before and between passes to open up pockets which may entrap slag or form voids.

f. Prepare tie-in area before welding to ensure proper fusion and fill-in.

g. Do not start or stop welds in corners, if possible. Start prior to or continue past the corner.

h. Backfill all craters to prevent crater cracks.

i. All legs of fillet joints should be of equal length unless otherwise noted on procedure sheets. The legs of fillet welds should be +1/16 inch. Reinforcements and melt through should be 3/32 in. maximum.

k. Prior to the application of any successive overlaying weld pass, the previous weld pass will be visually inspected by welder for contour and any evidence of porosity, slag, or lack of fusion. All defects will be repaired and the weld cleaned before making additional overlaying pass.

CHAPTER 2

REPAIR WELDING PROCEDURES

2-1. Preparation for Welding.

CAUTION

Do not use abrasive wheels on aluminum. Use only new tools, stainless steel wire brushes, and rotary files that have not been previously used on other metal s.

a. Surface preparation for repair welding requires removal of paint, grease, dirt, or any foreign material which would tend to degrade the quality of the weld. This can be accomplished by using a suitable paint solvent.

b. Joint preparation for repair welding is dependent upon the nature the defect, the material, and joint geometry. When a defect appears at near a weld, the old material should removed by using rotary files or by chipping.

2-2. Crack Determination.

a. During visual checks, cracks be indicated by localized peeling, flaking, or cracking of paint. To verify the existence of cracks, pair may be removed from suspect areas with solvents. To further identify the crack and its pattern, a dye penetrant may be applied. In general, if the surface or weld happens to be covers with grease or oil, developing crack will be further accentuated by the presence of dust.

b. When the crack length is defined, drill appropriately sized stopper holes at ends of the crack. These holes should be at least equal to the metal thickness, but not larger than weld used for repair. The stopper holes should be drilled as soon as crack is defined to prevent further cracking.

2-3. Welding.

NOTE

Stress relief procedures required during factory assembly are not practical for field use. Therefore, no stress relief procedures are recommended for field repair.

a. The type of weld required will depend on the structural member to be welded, in terms of material, size, joint geometry, and defect (which could range from a minute crack in a thin plate to the separation of chunks of material).

b. The structural material of the M198 howitzer consists of steel and aluminum. SMAII (MIG or TIG) process is generally used for steel, however it can be used for aluminum members. GTAW is also used for aluminum alloy members.

c. For depositing large amounts of aluminum filler material, GMAW is recommended, during which filler material is fed manually into area to be repaired.

CHAPTER 3
INDIVIDUAL WELD PROCEDURES

3-1. Multiple Passes. The following instructions apply to welding when multiple passes are used.

CAUTION

Do not use grinding equipment to clean weld.

a. Clean weld before and between passes. Open pockets which may entrap slag or form voids.

b. Use stainless steel brushes for removal of oxide and use carbide cutters for removal of base material

c. All areas that are questionable upon visual inspection after normal repair welding has been completed will be subjected to dye penetrant inspection.

3-2. Cradle (12007903).

CAUTION

When repair welding between block (12007939), channel (12007937), and plate (12007938) extreme care should be exercise to avoid contaminants.

a. All filler material is to be removed from block (12007939), channel (12007937), and plate (12007938) by using an air chisel or rotary file.

b. Tack weld block while travel lock assembly is in travel position.

c. Remove travel lock assembly and complete weld in the following manner

NOTE

Refer to figures 1 thru 4 for repair weld requirements.

(1) Make one pass on channel (12007937) to block (12007939) on the sides.

(2) Make one pass on plate (12007938) to channel (12007937) the width of plate.

(3) Make one pass on the channel (12007937) on all three sides.

3-3. Travel Lock Assembly (12008450).

a. Repair to cracks occurring in welds joining block (12007939) to channel (12007937) and channel (12007937) to plate (12007938) will be made in accordance with figures 1 thru 4.

b. All filler material will be removed completely from the entire side containing the cracks using an air chisel or rotary file.

c. Assemble travel lock assembly in travel position, making sure assembly is possible without difficulty. Assemble travel lock assembly in firing position and make sure it swings up into position without interference.

3-4. Frame (12008449).

a. Where possible, all filler material will be completely removed from cracked areas by an air chisel or rotary file. Before repair welding travel lock assembly, tubes and plates will be straightened and travel lock assembly placed on a flat surface. Use a work bench, if available, and clamp travel lock assembly to it prior to final welding. Refer to figures 7 thru 11 for welding procedure.

b. Repeated welds may not be made to the same joint or member if the following conditions are observed:

(1) Excessive distortion between ends, plates, and tubes that prevents travel lock assembly from engaging in lower clevis bracket.

3-4. Frame (12008449).--Continued

(2) Member burnout. No member burnout will be allowed.

c. If straightening of frame assembly is not possible, replace the travel lock assembly (12008450).

3-5. Spade Brackets (Right/Left12009198/12009199).

NOTE

If one spade bracket fails, replace all four spade brackets using two repair kits (12009201) in accordance with figures 17 thru 20.

When damage to spade brackets is such that complete replacement is necessary of either right spade bracket (120091 or left spade bracket (12009199), perform the following steps:

(1) Remove remaining failed spa bracket from trail assembly using an air chisel, rotary file, or by chipping.

(2) File all filler material until flush with surface of trail assembly.

CAUTION

The area to be welded must be clean and free of contaminants (paint, grease, etc.).

(3) With wheels down, apply parking brake.

(4) To facilitate welding, spread trail assemblies and raise spade bracket of trail assembly approximately 3 feet above ground.

(5) Install spade brackets on weapon and engage wedge enough to allow side-to-side movement of spade bracket relative to the trail assembly.

NOTE

Bushings (12009200) are part of the repair kit (12009201).

(6) Install bushings (12009200) in spade bracket holes (fig. 18).

(7) Pull handles (12008642) back to extreme position and position spade brackets against trail assemblies between trail and spade hinge, making sure that each bushing lines up with pin (12008640). Push handles in to insert pins into holes in brackets in accordance with figure 16.

(8) Tighten key (12008603) to accept quick release pin (MS17990C633) in accordance with figure 15.

(9) Tack weld two places in accordance with figures 15 thru 17.

(10) Remove spade assembly; complete weld in accordance with figures 15 thru 17.

3-6. Firing Assembly Baseplate (12008500).

a. Where possible, all filler material will be removed completely from cracked area by an air chisel or rotary file. Before repair welding, plates will be straightened and the members to be welded brought together, clamped, and tack welded in accordance with figures 12 and 13.

b. All bottom plate welds will be filed flush to surface adjacent to repair weld.

c. Repeated welds may not be made to the same joint or member if the following conditions are observed:

(1) Excessive distortion or cracks that prevent the baseplate from being stowed on trail assemblies between spade brackets. The baseplate will be straightened and welded.

(2) Member burnout. No member burnout will be allowed.

d. If straightening is not possible, or cracked areas are not repairable, the firing assembly baseplate will be replaced.

REPAIR WELD PROCEDURES FOR M198 HOWITZER
WELDING PARAMETERS

MAJOR SUBASSEMBLY SUBASSEMBLY	Cradle assembly Cradle	PART NO. 12008200 12007903
TYPICAL MEMBER	Plate Channel Block	12007938 12007937 12007939
MEMBER MATERIAL	Aluminum alloy 5086, QQ-A-250/7 or 5083 QQ-A-250/6	
MATERIAL THICKNESS	Plate 11.00 x 8.75, Channel 10.62 x 8.88 x 3.56 x 0.19, Block 3.56 x 2.38 x 6.00	
FILLER MATERIAL SIZE	5356 or 5556 3/64 (0.047)	
POSITION	Overhead	
PROCESS	MIG	
PREHEAT	Not required. See para 1-5b	
AMPERAGE	150-200	
VOLTAGE	15-25	
CURRENT	DCRP	
TRAVEL SPEED	Manual	
SHIELDING GAS	Argon 40-50 CFH	
STRESS RELIEF	Not practical in field repair	

- NOTES: 1. EXTEND WELD 1/2 INCH BEYOND END OF CRACKS.
2. CHANNEL 12007936 BETWEEN PLATE 12007938 AND CHANNEL 12007939 IS NOT SHOWN FOR CLARITY

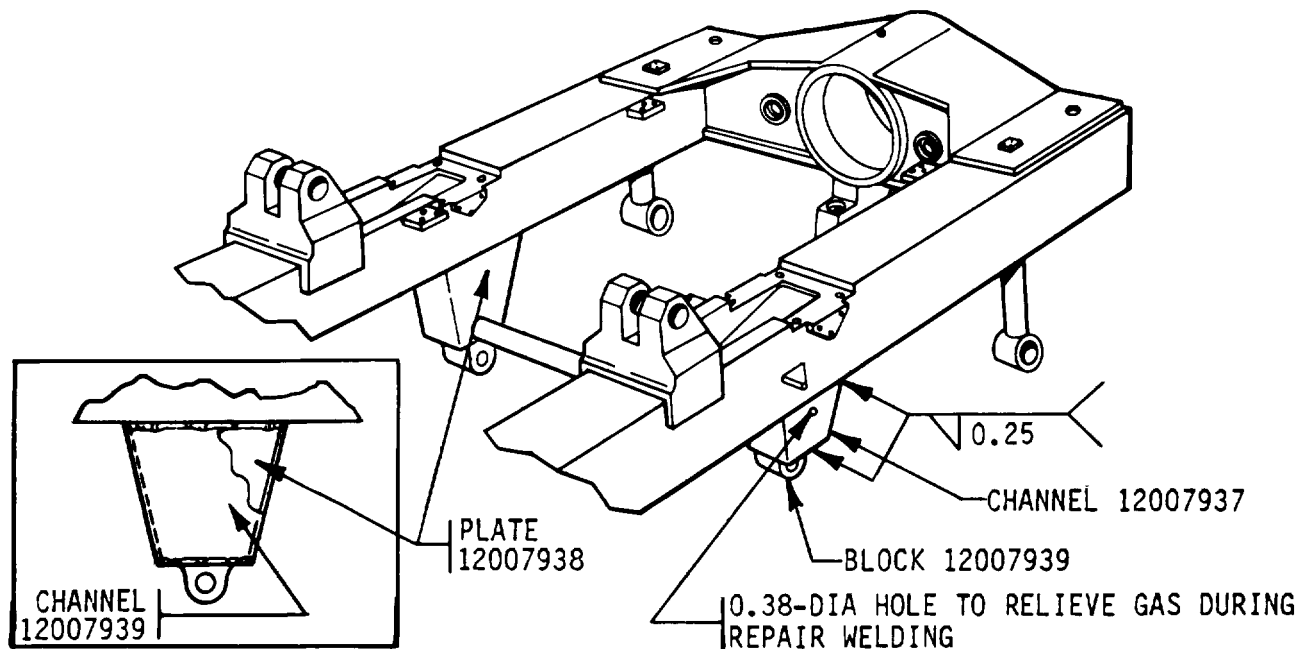

Figure 1. General areas for repair welding.

REPAIR WELD PROCEDURES FOR M198 HOWITZER
WELDING PARAMETERS

MAJOR SUBASSEMBLY	Cradle assembly	PART NO.
SUBASSEMBLY	Cradle	12008200
TYPICAL MEMBER	Channel	12007937
MEMBER MATERIAL	Aluminum alloy 5086 QQ-A-150/7 or 5083 QQ-A-250/6	
MATERIAL THICKNESS	10.62 x 8.88 x 3.56 formed from plate	
FILLER MATERIAL	5356 or 5556	
SIZE	3/64 (0.047)	
POSITION	Overhead	
PROCESS	MIG	
PREHEAT	Not required. See para 1-5b	
AMPERAGE	150-200	
VOLTAGE	15-25	
CURRENT	DCRP	
TRAVEL SPEED	Manual	
SHIELDING GAS	Argon 40-50 CFH	
STRESS RELIEF	Not practical in field repair	

- NOTES: 1. EXTEND WELD 1/2 INCH BEYOND END OF CRACKS.
2. CHANNEL 12007936 IS SHOWN BECAUSE IT MAY AFFECT HEATING OF TYPICAL MEMBER

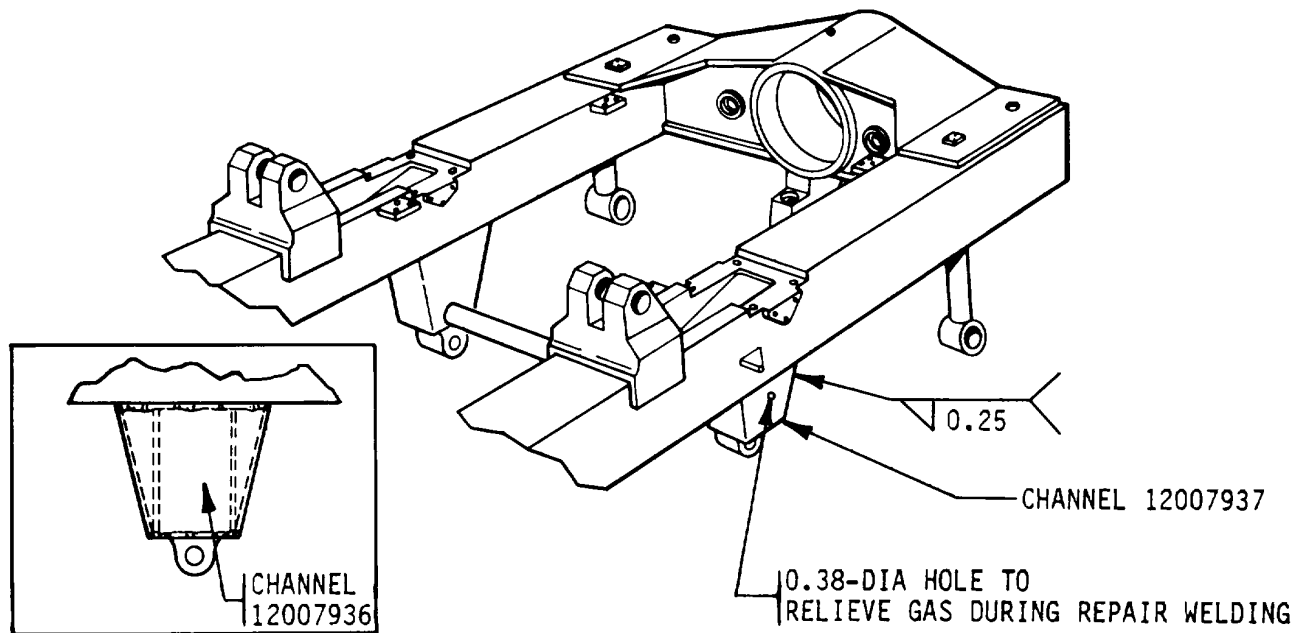

Figure 2. Repair welding procedure for channel 12007937.

REPAIR WELD PROCEDURES FOR M198 HOWITZER
WELDING PARAMETERS

MAJOR SUBASSEMBLY		PART NO.
SUBASSEMBLY	Cradle assembly	12008200
	Cradle	12007903
TYPICAL MEMBER	Plate	12007938
MEMBER MATERIAL	Aluminum alloy 5086 QQ-A-250/7 or 5083 QQ-A-250/6	
MATERIAL THICKNESS	11.00 x 8.75 member size 0.25-in. thick	
FILLER MATERIAL	5356 or 5556	
SIZE	3/64 (0.047)	
POSITION	Overhead	
PROCESS	MIG	
PREHEAT	Not required. See para 1-5b	
AMPERAGE	150-200	
VOLTAGE	15-25	
CURRENT	DCRP	
TRAVEL SPEED	Manual	
SHIELDING GAS	Argon 40-50 CFH	
STRESS RELIEF	Not practical in field repair	

- NOTES: 1. EXTEND WELD 1/2 INCH BEYOND END OF CRACKS.
2. CHANNEL 12007936 IS SHOWN BECAUSE IT MAY AFFECT HEATING OF TYPICAL MEMBER

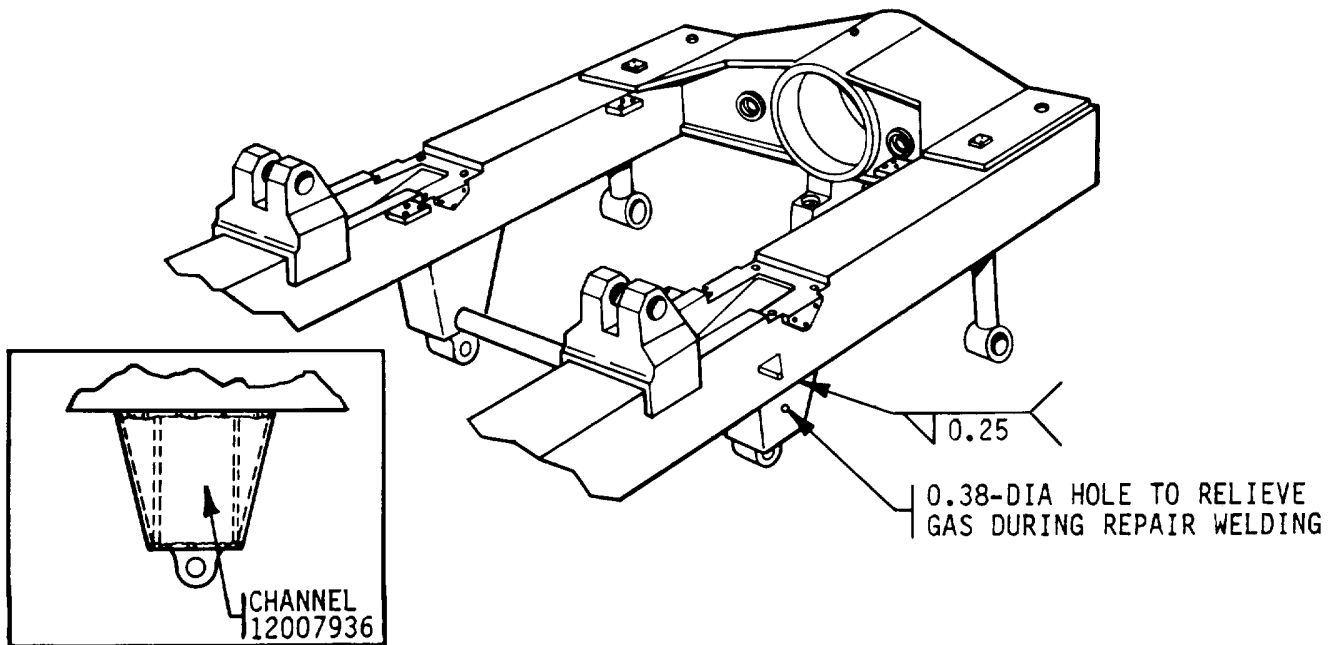

Figure 3. Repair welding procedure for plate 12007938.

REPAIR WELD PROCEDURES FOR M198 HOWITZER

WELDING PARAMETERS

MAJOR SUBASSEMBLY		PART NO.
SUBASSEMBLY	Cradle assembly	12008200
	Cradle	12007903
TYPICAL MEMBER	Block	12007939
MEMBER MATERIAL	Aluminum alloy, 5083 QQ-A-250/6 or QQ-A-250-7 or 5086 QQ-A-250/4 or QQ-A-25/5	
MATERIAL THICKNESS	3.56 x 2.38 x 6.00	
FILLER MATERIAL	5356 or 5556	
SIZE	3/64 (0.047)	
POSITION	Overhead	
PROCESS	MIG	
PREHEAT	Not required. See para 1-5b	
AMPERAGE	150-200	
VOLTAGE	15-25	
CURRENT	DCRP	
TRAVEL SPEED	Manual	
SHIELDING GAS	Argon 40-50 CFH	
STRESS RELIEF	Not practical in field repair	

- NOTES: 1. EXTEND WELD 1/2 INCH BEYOND END OF CRACKS.
 2. CHANNEL 12007936 IS SHOWN BECAUSE IT MAY AFFECT HEATING OF TYPICAL MEMBER.

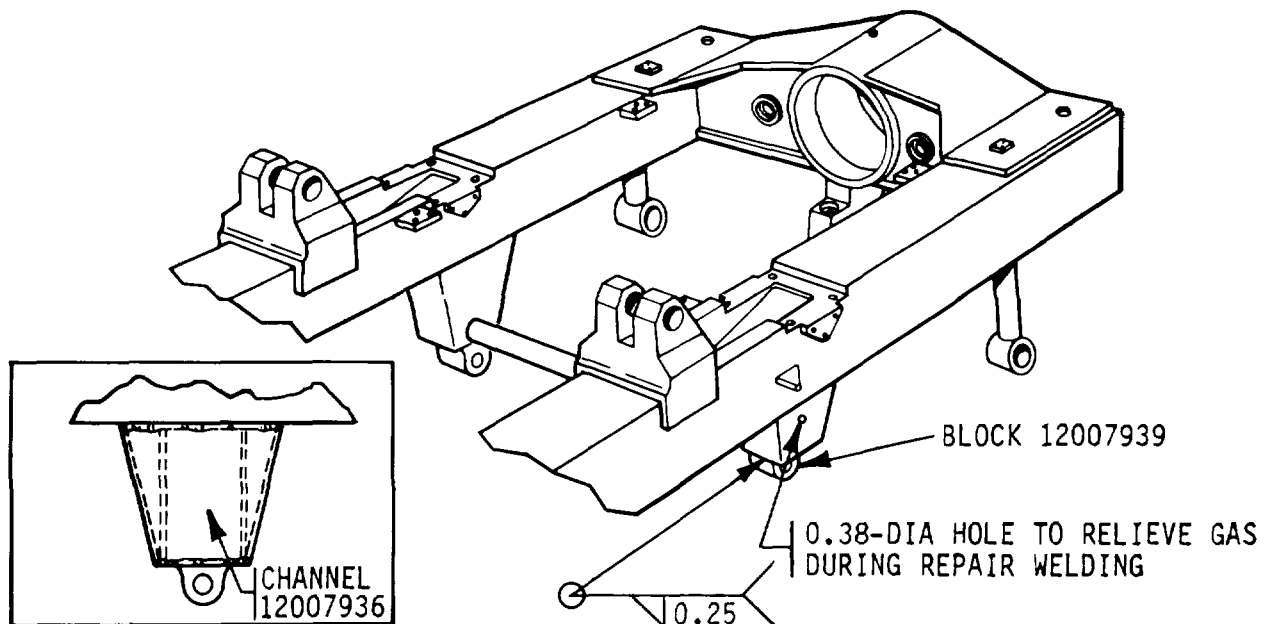

Figure 4. Repair welding procedure for block 12007939.

REPAIR WELD PROCEDURES FOR M198 HOWITZER
WELDING PARAMETERS

MAJOR SUBASSEMBLY		PART NO.
SUBASSEMBLY	Bottom carriage assembly	12008300
	Bottom carriage	12008380
TYPICAL MEMBER	Travel lock assembly brackets	12008530
		12008531
MEMBER MATERIAL	Steel casting class 105-85	
MATERIAL THICKNESS	Flange thickness 0.38-in.	
FILLER MATERIAL	E7018 or E70S-3	
SIZE	7/32 or 3/32 (0.219 or 0.094)	
POSITION	Flat or horizontal	
PROCESS	SMAW	
PREHEAT	Not required. See para 1-5b	
AMPERAGE	90-130	
VOLTAGE	25-36	
CURRENT	DCRP	
TRAVEL SPEED	Manual	
SHIELDING GAS	None	
STRESS RELIEF	Not practical in field repair	

NOTE: EXTEND WELD ½ INCH BEYOND ENDS OF CRACK.

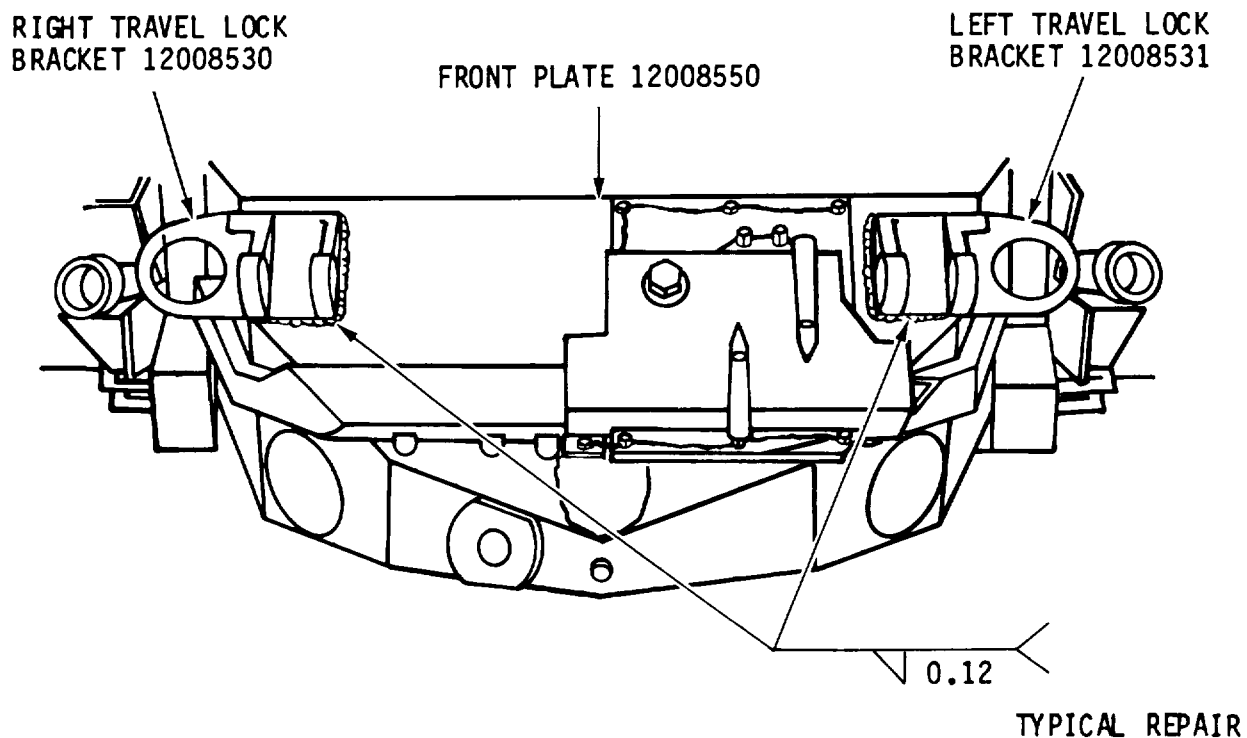

Figure 5. Repair welding procedure for travel lock assembly brackets 12008530 and 12008531.

REPAIR WELD PROCEDURES FOR M198 HOWITZER
WELDING PARAMETERS

MAJOR SUBASSEMBLY	Bottom carriage assembly	PART NO.
SUBASSEMBLY	Bottom carriage	12008300 12008380
TYPICAL MEMBER	Front plate	12008550
MEMBER MATERIAL	Alloy steel sheet grade A ASTM A710	
MATERIAL THICKNESS	0.12-in. stock	
FILLER MATERIAL	E7018 or E70S-3	
SIZE	7/32 or 3/32 (0.219 or 0.094)	
POSITION	Flat OH or V	
PROCESS	SMAW	
PREHEAT	Not required. See para 1-5b	
AMPERAGE	90-130 60-100	
VOLTAGE	25-36 20-30	
CURRENT	DCRP	
TRAVEL SPEED	Manual	
SHIELDING GAS	None	
STRESS RELIEF	Not practical in field repair	

NOTE: EXTEND WELD 1/2 INCH BEYOND ENDS OF DEFECT.

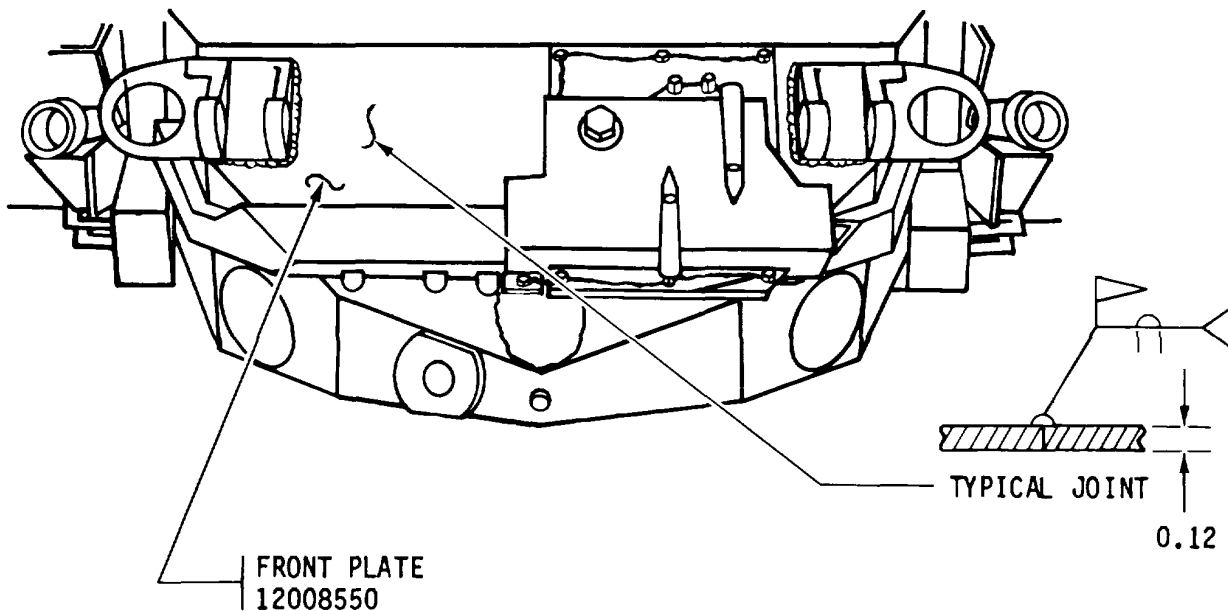

Figure 6. Repair welding procedure for cracks in front plate 12008550.

REPAIR WELD PROCEDURES FOR M198 HOWITZER
WELDING PARAMETERS

MAJOR SUBASSEMBLY SUBASSEMBLY	Travel lock assembly Frame	PART NO. 12008450 12008449
TYPICAL MEMBER	End Plate Tube	12008446 12008442 12008445
MEMBER MATERIAL	Aluminum alloy 6061T6	
MATERIAL THICKNESS	0.09-in.	
FILLER MATERIAL	4043 or 5356	
SIZE	3/64 (0.047)	
POSITION	Horizontal	
PROCESS	MIG	
PREHEAT	Not required. See para 1-5b	
AMPERAGE	150-200	
VOLTAGE	15-25	
CURRENT	DCRP	
TRAVEL SPEED	Manual	
SHIELDING GAS	Argon 40-50 CFH	
STRESS RELIEF	Not practical in field repair	

NOTES:

1. WELD FROM PLATE TO PLATE.
2. EXTEND WELD 1/2 INCH BEYOND ENDS OF CRACKS.

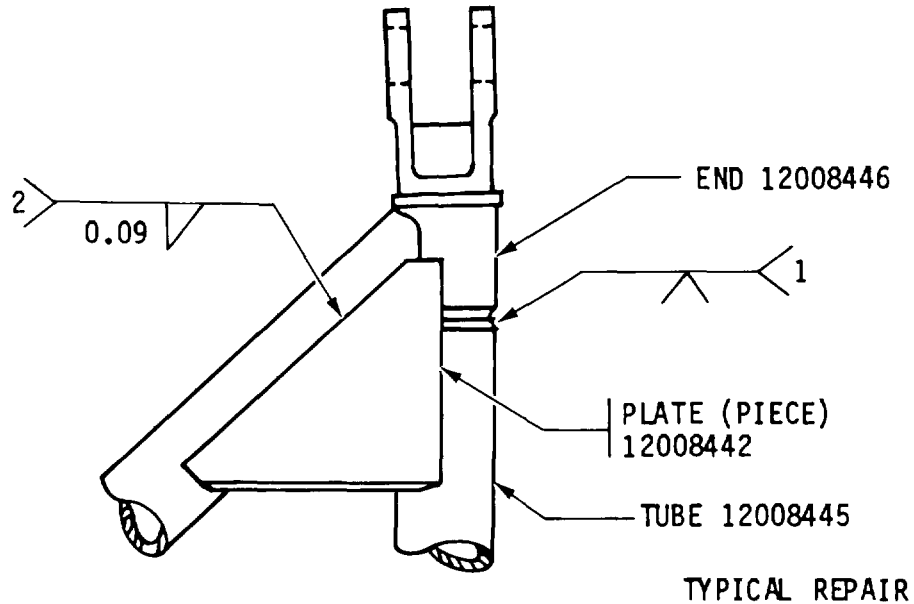

Figure 7. Repair welding procedure for tube 12008445 to plate 12008442.

REPAIR WELD PROCEDURES FOR M198 HOWITZER
WELDING PARAMETERS

MAJOR SUBASSEMBLY		PART NO.
SUBASSEMBLY	Travel lock assembly Frame	12008450 12008449
TYPICAL MEMBER	Plate	12008442
MEMBER MATERIAL	Aluminum alloy 6061T6	
MATERIAL THICKNESS	0.09-in.	
FILLER MATERIAL	4043 or 5356	
SIZE	3/64 (0.047)	
POSITION	Flat on work bench or in holding fixture	
PROCESS	MIG	
PREHEAT	Not required. See para 1-5b	
AMPERAGE	150-200	
VOLTAGE	15-25	
CURRENT	DCRP	
TRAVEL SPEED	Manual	
SHIELDING GAS	Argon 40-50 CFH	
STRESS RELIEF	Not practical in field repair	

- NOTES: 1. WELD FROM PLATE TO PLATE.
2. EXTEND WELD 1/2 INCH BEYOND ENDS OF CRACKS.

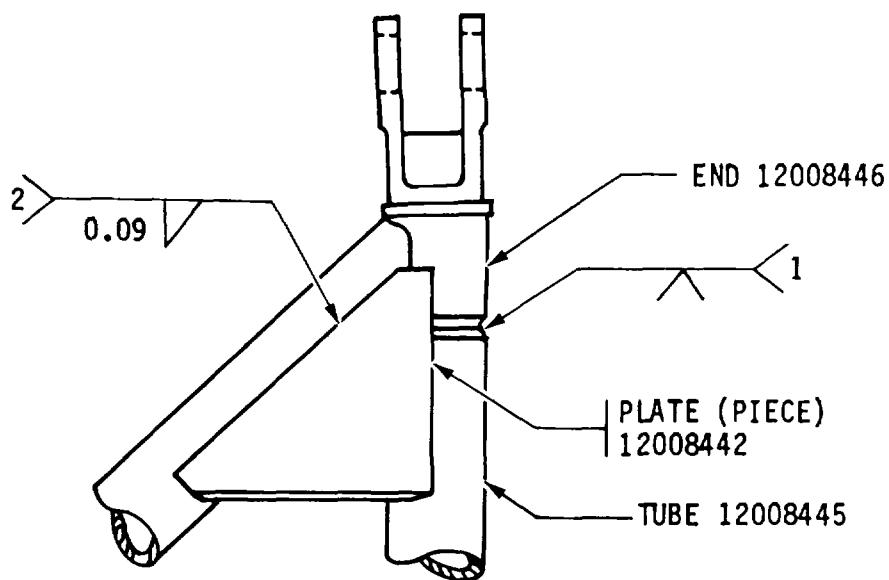

Figure 8. Repair welding procedure for plate 12008442 to end 12008446.

REPAIR WELD PROCEDURES FTR M198 HOWITZER
WELDING PARAMETERS

MAJOR SUBASSEMBLY		PART NO.
SUBASSEMBLY	Travel lock assembly	12008450
	Frame	12008449
TYPICAL MEMBER	End	12008446
MEMBER MATERIAL	Aluminum alloy 6061T6 QQ-A-367	
MATERIAL THICKNESS	3.5 x 10.33 block - 2.5 Dia	
FILLER MATERIAL	4043 or 5356	
SIZE	3/64 (0.047)	
POSITION	Horizontal or vertical	
PROCESS	MIG	
PREHEAT	Not required. See para 1-5b	
AMPERAGE	150-200	
VOLTAGE	15-25	
CURRENT	DCRP	
TRAVEL SPEED	Manual	
SHIELDING GAS	Argon 40-50 CFH	
STRESS RELIEF	Not practical in field repair	

- NOTE: 1. WELD FROM PLATE TO PLATE.
2. EXTEND WELD 1/2 INCH BEYOND ENDS OF CRACKS.

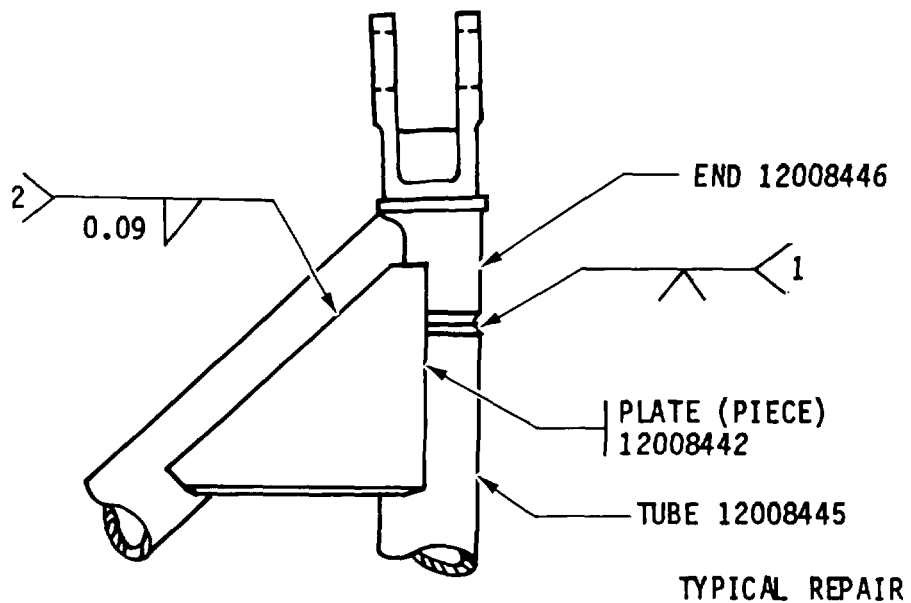

Figure 9. Repair welding procedure for tube 12008445 to end 12008446.

REPAIR WELD PROCEDURES FOR M198 HOWITZER
WELDING PARAMETERS

MAJOR SUBASSEMBLY		PART NO.
SUBASSEMBLY	Travel lock assembly Frame	12008450 12008449
TYPICAL MEMBER	End	12008447
MEMBER MATERIAL	6061T6	
MATERIAL THICKNESS	11.46 x 3.12 x 2.38 Piece	
FILLER MATERIAL	4043 or 5356	
SIZE	3/64 (0.047)	
POSITION	Flat on work bench or in holding fixture	
PROCESS	MIG	
PREHEAT	Not feasible in field application	
AMPERAGE	120-225	
VOLTAGE	20-25	
CURRENT	DCRP	
TRAVEL SPEED	Manual	
SHIELDING GAS	Argon 40-50 CFH	
STRESS RELIEF	Not practical in field repair	

NOTE: WELD FROM PLATE TO PLATE.

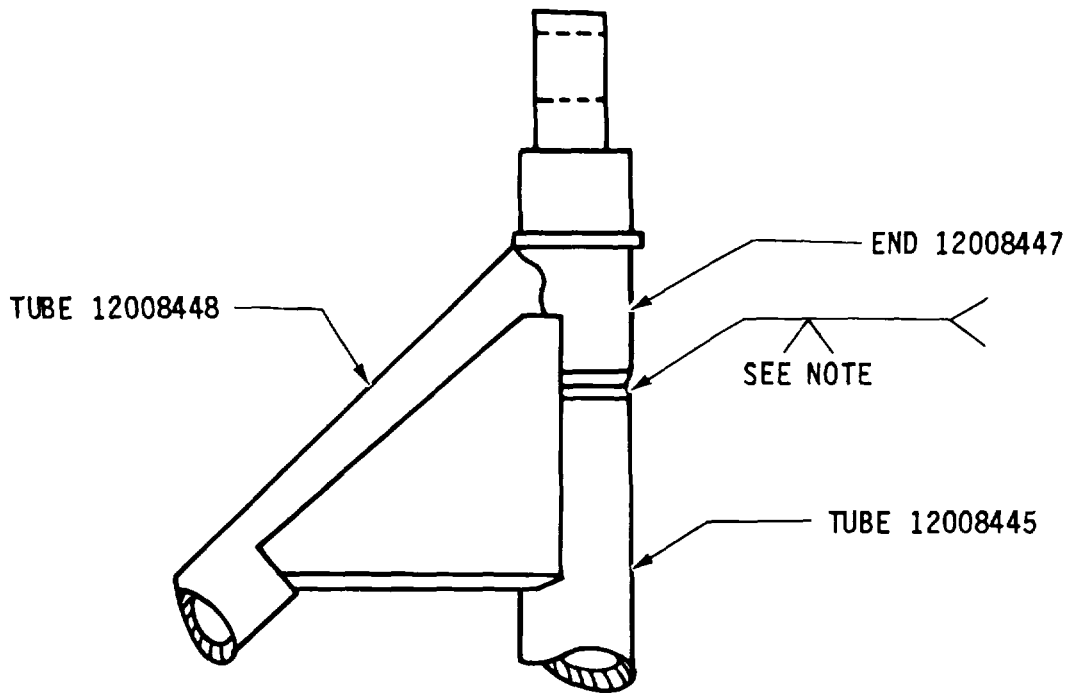

Figure 10. Repair welding procedure for tube 12008448 to end 12008447.

REPAIR WELD PROCEDURES FOR M198 HOWITZER
WELDING PARAMETERS

MAJOR SUBASSEMBLY		PART NO.
SUBASSEMBLY	Travel lock assembly	12008450
	Frame	12008449
TYPICAL MEMBER	Tube	12008448
MEMBER MATERIAL	Aluminum alloy seamless tubing 6061T6 type 1. spec WW-T-700/6	
MATERIAL THICKNESS	0.25-in. wall	
FILLER MATERIAL	4043 or 5356	
SIZE	3/64 (0.047)	
POSITION	Horizontal or vertical	
PROCESS	MIG	
PREHEAT	Not required. See para 1-5b	
AMPERAGE	150-200	
VOLTAGE	15-25	
CURRENT	DCRP	
TRAVEL SPEED	Manual	
SHIELDING GAS	Argon 40-50 CFH	
STRESS RELIEF	Not practical in field repair	

NOTE: EXTEND WELDS 1/2 INCH BEYOND ENDS OF CRACKS.

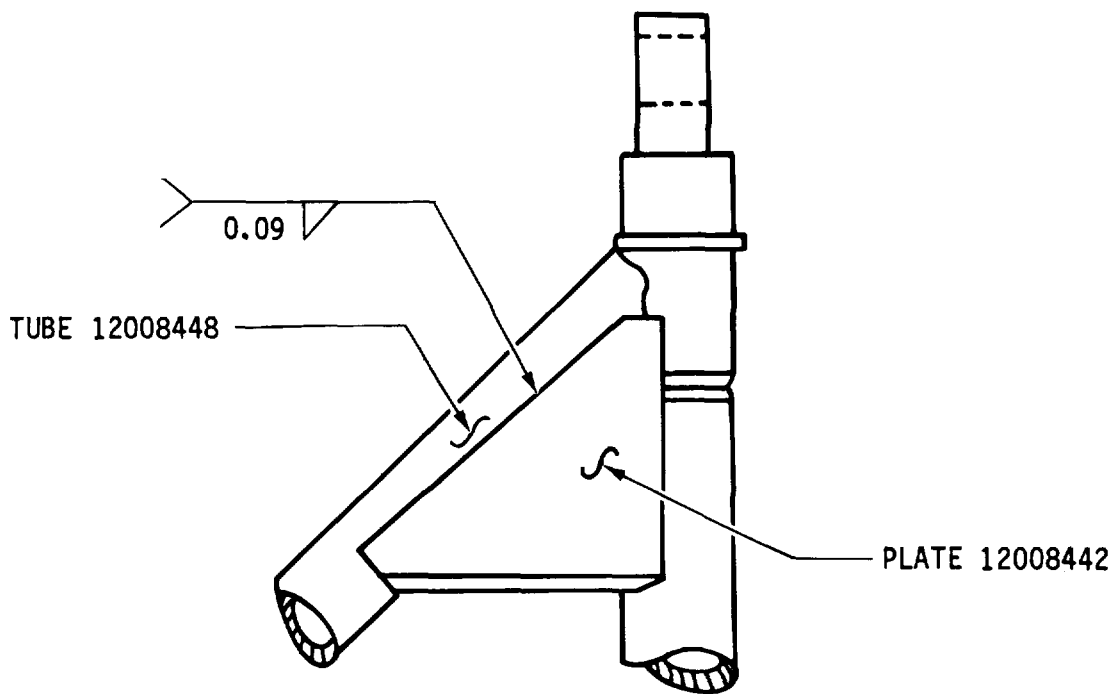

Figure 11. Repair welding procedure for plate 12008442 to tube 12008448.

REPAIR WELD PROCEDURES FOR M198 HOWITZER
WELDING PARAMETERS

MAJOR SUBASSEMBLY	Bottom carriage assembly	PART NO.
SUBASSEMBLY	Firing assembly baseplate	12008300 12008500
TYPICAL MEMBER	Plate (bottom)	12008513
MEMBER MATERIAL	Aluminum alloy 5083, H321 or H323 spec QQ-A-250/6 or aluminum alloy 5086, H32 or H34 spec QQ-A-250/7	
MATERIAL THICKNESS	0.19+0.026 in.	
FILLER MATERIAL	5356 or 5556	
SIZE	3/64 (0.047)	
POSITION	Flat	
PROCESS	MIG	
PREHEAT	Not required. See para 1-5b	
AMPERAGE	125-225	
VOLTAGE	20-24	
CURRENT	DCRP	
TRAVEL SPEED	Manual	
SHIELDING GAS	Argon 40-50 CFH	
STRESS RELIEF	Not practical in field repair	

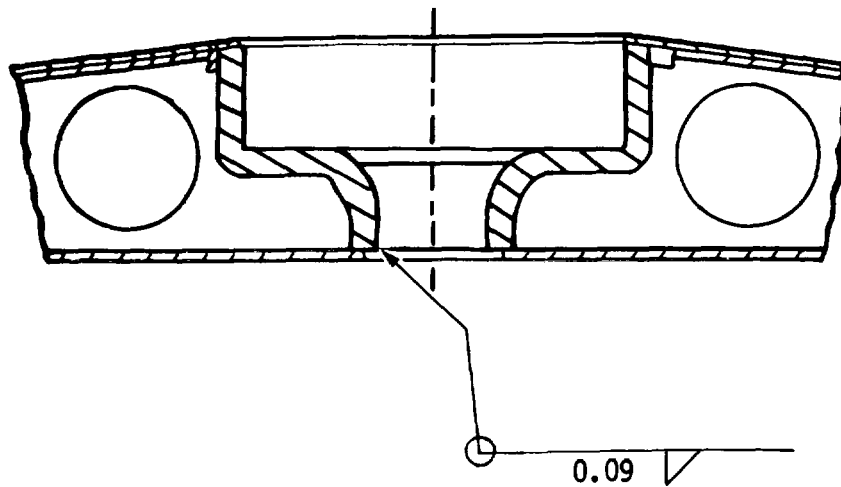

Figure 12. Repair welding procedure for cracks in bottom plate 12008513 to support 12008501.

REPAIR WELD PROCEDURES FOR M198 HOWITZER
WELDING PARAMETERS

MAJOR SUBASSEMBLY		PART NO.
SUBASSEMBLY	Bottom carriage assembly	12008300
	Firing assembly baseplate	12008500
TYPICAL MEMBER	Bottom plate	12008513
MEMBER MATERIAL	Aluminum alloy 5083, H321 or H323 spec QQ-A-250/6 or aluminum alloy 5086, H32, or H34, spec QQ-A-250/7	
MATERIAL THICKNESS	0.190+0.026 in.	
FILLER MATERIAL	5356 or 5556	
SIZE	3/64 (0.047)	
POSITION	Flat	
PROCESS	MIG	
PREHEAT	Not required. See para 1-5b	
AMPERAGE	125-225	
VOLTAGE	20-24	
CURRENT	DCRP	
TRAVEL SPEED	Manual	
SHIELDING GAS	Argon 40-50 CFH	
STRESS RELIEF	Not practical in field repair	

NOTES: 1. WELD ALL CRACKS.

2. FILE WELDS FLUSH WITH SURFACE OF PARENT METAL.

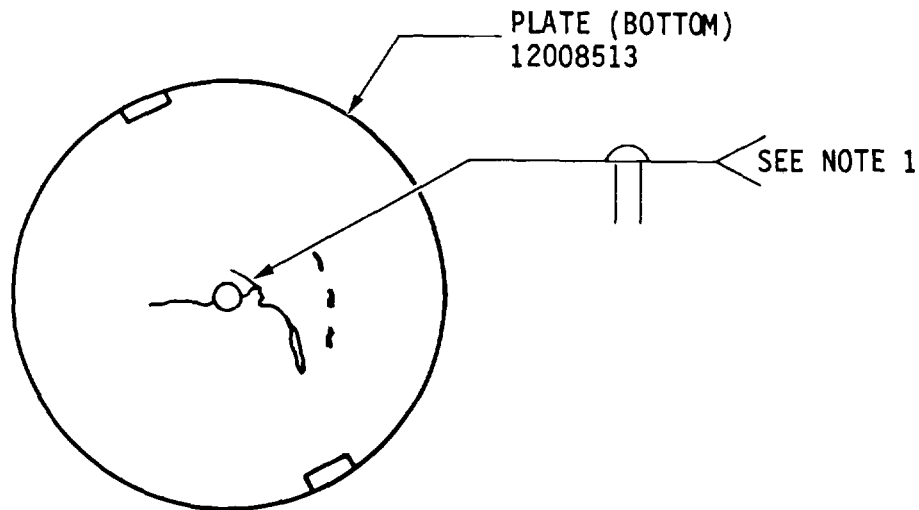

Figure 13. Repair welding procedure for cracks in bottom plate 12008513.

REPAIR WELD PROCEDURES FOR M198 HOWITZER
WELDING PARAMETERS

MAJOR SUBASSEMBLY	Bottom carriage assembly	PART NO.
SUBASSEMBLY	Firing assembly baseplate	12008300 12008500
TYPICAL MEMBER	Plate (top)	12008514
MEMBER MATERIAL	Aluminum alloy 5083, H321, or H323 spec QQ-A-250/6 or aluminum alloy 5086 H32, or H34 spec QQ-A-250/7	
MATERIAL THICKNESS	0.120+0.020 in.	
FILLER MATERIAL	5356 or 5556	
SIZE	3/64 (0.047)	
POSITION	Flat	
PROCESS	MIG	
PREHEAT	Not required. See para 1-5b	
AMPERAGE	125-225	
VOLTAGE	20-24	
CURRENT	DCRP	
TRAVEL SPEED	Manual	
SHIELDING GAS	Argon 40-50 CFH	
STRESS RELIEF	Not practical in field repair	

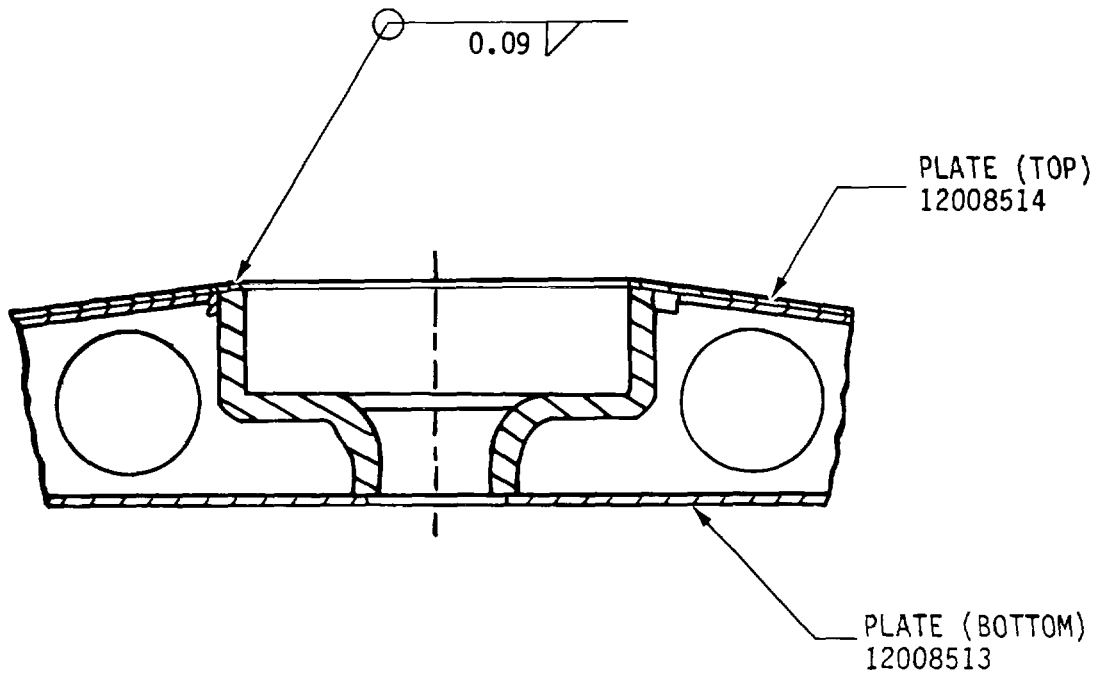

Figure 14. Repair welding procedure for top plate 12008514.

REPAIR WELD PROCEDURES FOR M198 HOWITZER
WELDING PARAMETERS

MAJOR SUBASSEMBLY	Bottom carriage assembly	PART NO.
SUBASSEMBLY	Trail assembly (right/left)	12008300 12008600/12008601
TYPICAL MEMBER	Bottom plate	12008795
MEMBER MATERIAL	Aluminum alloy 5083 or 5086	
MATERIAL THICKNESS	From 0.25 in. spade end to 0.50 in. hinge end	
FILLER MATERIAL	5356 or 5556	
SIZE	3/64 (0.047)	
POSITION	Vertical overhead	
PROCESS	MIG	
PREHEAT	Not required. See para 1-5b	
AMPERAGE	180-220	
VOLTAGE	15-25	
CURRENT	DCRP	
TRAVEL SPEED	Semiautomatic 20-24 (IPM)	
SHIELDING GAS	Argon 30-40 CFH	
STRESS RELIEF	Not practical in field repair	

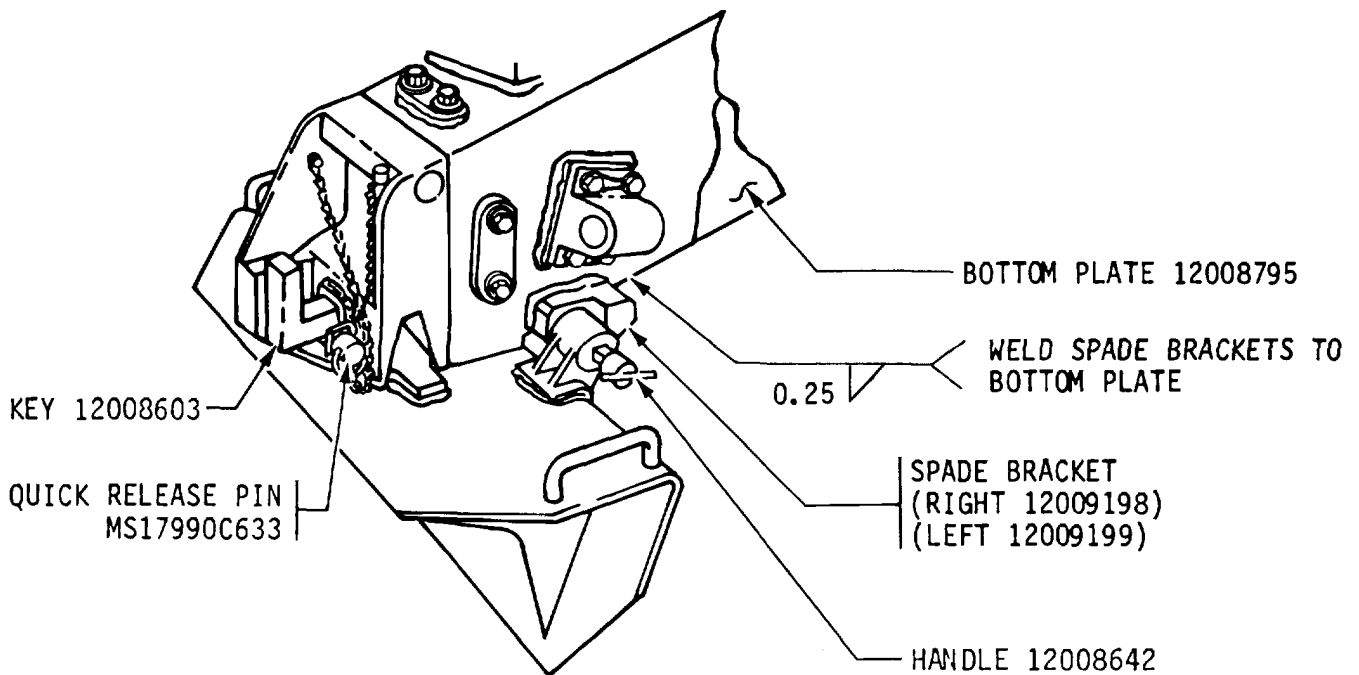

Figure 15. Repair welding procedure for bottom plate 12008795.

REPAIR WELD PROCEDURES FOR M198 HOWITZER
WELDING PARAMETERS

MAJOR SUBASSEMBLY	Bottom carriage assembly	PART NO.
SUBASSEMBLY	Trail assembly (right/left)	12008300 12008600/12008601
TYPICAL MEMBER	Side plate	12008799
MEMBER MATERIAL	Aluminum alloy 5083 or 5086	
MATERIAL THICKNESS	Plate 0.25-in.	
FILLER MATERIAL	5356 or 5556	
SIZE	3/64 (0.047)	
POSITION	Vertical overhead	
PROCESS	MIG	
PREHEAT	Not required. See para 1-5b	
AMPERAGE	180-220	
VOLTAGE	15-25	
CURRENT	DCRP	
TRAVEL SPEED	Semiautomatic 20-24 (IPM)	
SHIELDING GAS	Argon 30-40 CFH	
STRESS RELIEF	Not practical in field repair	

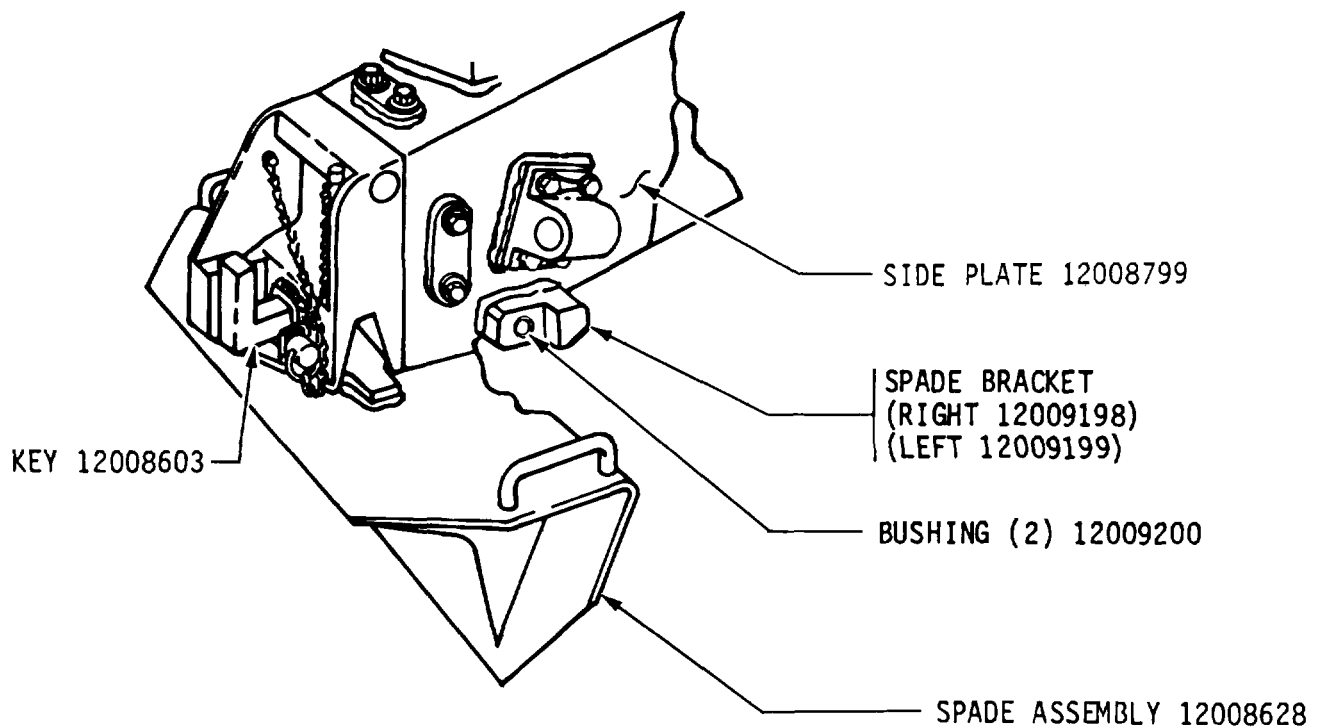

Figure 16. Repair welding procedure for side plate 12008799.

REPAIR WELD PROCEDURES FOR M198 HOWITZER
WELDING PARAMETERS

MAJOR SUBASSEMBLY	Bottom carriage assembly	PART NO.
SUBASSEMBLY	Trail assembly (right/left)	12008300 12008600/12008601
TYPICAL MEMBER	Spade bracket (right/left)	12009198/12009199
MEMBER MATERIAL	Aluminum alloy 5086 temper 0, or H112, spec QQ-A-200 or 5083 temper 0 or H112 spec QQ-A-200/4	
MATERIAL THICKNESS	Block 3.75 in. x 2.5 in. x 2.5 in. w/1.50 1.37 deep	
FILLER MATERIAL	5356 or 5556	
SIZE	3/64 (0.047)	
POSITION	Vertical overhead	
PROCESS	MIG	
PREHEAT	Not required. See para 1-5b	
AMPERAGE	180-220	
VOLTAGE	15-25	
CURRENT	DCRP	
TRAVEL SPEED	Semiautomatic 20-24 (IPM)	
SHIELDING GAS	Argon 30-40 CFH	
STRESS RELIEF	Not practical in field repair	

NOTES: 1. REMOVE SPADE AND CONTINUE WELD.

2. TRAIL ASSEMBLY, SERIAL NO. 10 THRU 28, RIGHT/LEFT 12008600/12008601.

3. TRAIL ASSEMBLY, SERIAL NO. 29 AND UP, RIGHT/LEFT 12009107/12009108.

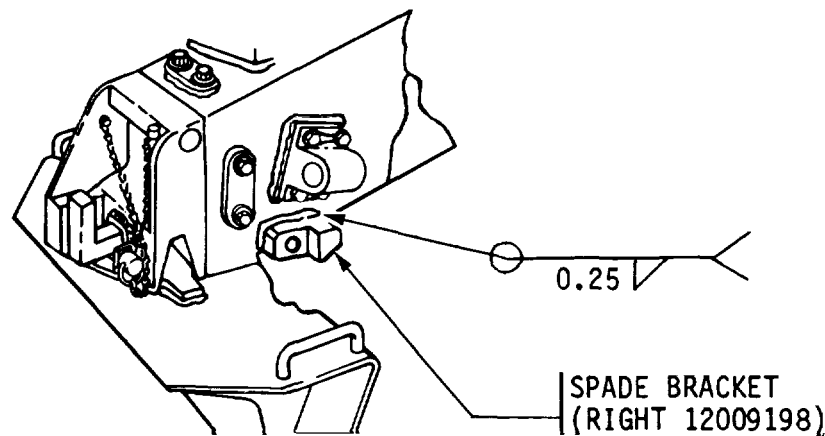

Figure 17. Repair welding procedure for spade brackets3-19 (right/left) 12009198/12009199.

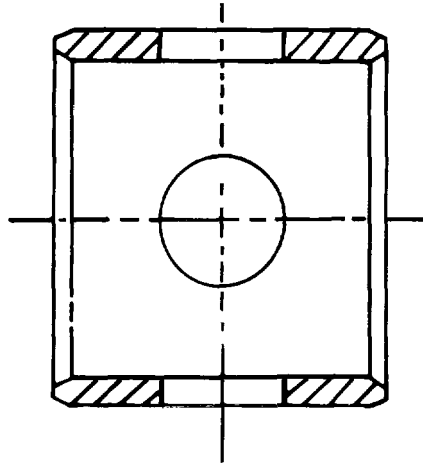

Figure 18. Bushing (12009200) for spade bracket. (Part of repair kit 12009201)

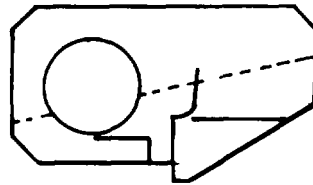

Figure 19. Right spade bracket 12009198. (Part of repair kit 12009201)

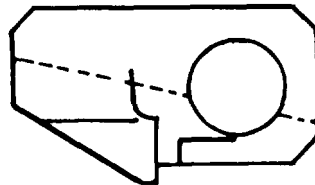

Figure 20. Left spade bracket 12009199. (Part of repair kit 12009201)

**APPENDIX A
REFERENCES**

A-1. Forms and Other Publications. The following forms and publications are related to information-contained in this bulletin.

DA Form 2028Recommended Changes to Publications and Blank Forms

DA Form 2028-2Recommended Changes to Equipment Technical Publications

MIL-STD-248CWelding and Brazing Procedure and Performance Qualification

By Order of the Secretary of the Army:

JOHN A. WICKHAM, JR.
General, United States Army
Chief of Staff

Official:

DONALD I. DELANDRO
Brigadier General, United States Army
The Adjutant General

Distribution:

To be distributed in accordance with DA Form 12-40, Direct and General Support Maintenance requirements for Howitzer, 155-MM, Towed, M198.

*U.S. GOVERNMENT PRINTING OFFICE: 1985- 554-049, 10072

RECOMMENDED CHANGES TO EQUIPMENT TECHNICAL PUBLICATIONS



THEN... JOT DOWN THE DOPE ABOUT IT ON THIS FORM, CAREFULLY TEAR IT OUT, FOLD IT AND DROP IT IN THE MAIL!

SOMETHING WRONG WITH THIS PUBLICATION?

FROM: (PRINT YOUR UNIT'S COMPLETE ADDRESS)

DATE SENT

PUBLICATION NUMBER

PUBLICATION DATE

PUBLICATION TITLE

BE EXACT... PIN-POINT WHERE IT IS

PAGE NO.	PARA-GRAPH	FIGURE NO.	TABLE NO.
----------	------------	------------	-----------

IN THIS SPACE TELL WHAT IS WRONG AND WHAT SHOULD BE DONE ABOUT IT:

TEAR ALONG PERFORATED LINE

PRINTED NAME, GRADE OR TITLE, AND TELEPHONE NUMBER

SIGN HERE:

DA FORM 2028-2
1 JUL 79

PREVIOUS EDITIONS ARE OBSOLETE.

P.S.—IF YOUR OUTFIT WANTS TO KNOW ABOUT YOUR RECOMMENDATION MAKE A CARBON COPY OF THIS AND GIVE IT TO YOUR HEADQUARTERS.

